



# 中国·齐力控股集团 CHINA·QILI HOLDING GROUP

高洁净流体设备阀门及管道连接部件  
解决方案一站式专业制造商

PROFESSIONAL MANUFACTURER OF  
SANITARY FLUID VALVE & PIPE FITTING SOLUTIONS

中国·齐力控股集团有限公司  
CHINA·QILI HOLDING GROUP CO., LTD.  
安徽齐力不锈钢制品有限公司  
ANHUI QILI STAINLESS STEEL PRODUCTS CO., LTD.  
安徽齐力金属制品有限公司  
ANHUI QILI METAL PRODUCTS CO., LTD.

## 中国 CHINA

集团总部: 中国浙江省温州市滨海开发区滨海三路3839-1  
生产基地: 安徽省怀宁经济技术开发区兴业路1号  
锻造冲板基地: 安徽省怀宁经济开发区独秀大道32号  
电话: +86-577-86990175  
传真: +86-577-86990176  
邮箱: sales@wzqlqjx.cn  
网址: www.cnqlgroup.com www.cnqlstainless.com



小程序  
Applets



企业微信公众平台  
Official account



国内官网  
Website

## 国际 INTERNATIONAL

Headquarters: 3839-1 Binhai 3rd Road, Binhai Development Zone, Wenzhou, Zhejiang Province, China  
Mass Production Factory: No. 1 Xingye Road, Huaining Economic Development Zone, Anhui Province  
Forging & Punching Factory: No. 32 Duxiu Avenue, Huaining Economic Development Zone, Anhui Province  
Tel: +86-577-86990175  
Fax: +86-577-86990176  
E-mail: sales@wzqlqjx.cn  
Http: www.qlstainless.com www.sanitary-valve-fittings.com



国际官网  
Website





# 齐力创始人

## FOUNDER OF QILI

朱常有  
Beckham

齐力控股集团董事长  
Chairman of Qili Group



山东汉子朱常有在温创业20多年，以练武人的勤奋、刻苦、毅力，经过十多年的发展与沉淀，企业正式升级为集团公司，目前集团拥有8大生产企业，拥有外贸销售精英、技术研发人员，985、211高学历人才65人，员工总数400余人，产品远销欧洲、美国、加拿大、墨西哥、澳洲等70多个国家和地区，齐力控股集团已成为不锈钢卫生级领域的家喻户晓的企业。

朱董事长说“做企业对内要成就员工，改善员工生活就是一种社会责任，也体现了企业管理者的胸怀和大爱，对外成就客户，达成互惠、互利、共赢为目的。”公司之所以起名“齐力”，正是希望凝聚团队的力量，齐心协力创事业，朱董曾为家乡修桥铺路，山东寿光发洪水，2020年新冠疫情，2021年河南水灾，数次为灾区捐款捐物，企业做大要回馈社会。

### 荣获企业及个人荣誉

Enterprise and Personal Honor:

- 朱常有-齐力控股集团董事长-共产党员
- 齐力控股集团联合党支部书记
- 安徽齐力不锈钢制品党支部书记
- 温州市山东商会-常务副会长
- 龙湾区政协委员
- 温州市工商联-执委
- 经开区网球协会会长
- 龙湾区人民政府“优秀企业”
- “缘聚爱”公益联盟《爱心单位》
- 2020年度“杰出鲁商”
- 异地在温创业领军人物
- 温州市新居民企业称号
- 浙江省科技型中小企业
- 国家高新技术企业

From Heze City, Shandong, Zhu Changyou (Beckham) has run the business in Wenzhou for more than 20 years. With the diligence, hard work, and perseverance of martial arts practitioners, after more than ten years of development, and precipitation, the company officially leveled up to a group in 2021. Nowadays, the group has total 400 staffs and 68 highly educated staff working as exportation sales elites, and RD technicians; many are from the well-known University Project 985 and 211. Products are exported to more than 70 countries and regions such as Europe, Australia, North America, the Middle East, Southeast Asia, etc. By the end of May 2022, QILI has a staff of nearly 400. QILI Holding Group has become a well-known enterprise in the field of stainless steel sanitary fittings.

Chairman Zhu often says, "Being a company internally must achieve employees, and improving employees' lives which is not only a social responsibility but also reflects the mind and love of the corporate owner; externally, to fulfill customers by achieving mutual benefit and win-win situation is the goal." The reason for the name "QILI" is that he hopes to gather the strength of the team and work together to create the business. Chairman Zhu has helped pave the road in his hometown, donated for several natural disasters such as the flood in Shouguang, Shandong, the COVID-19 pandemic in 2020, the flood in Henan in 2021, also helping to alleviate poverty. As a company grows, we have social responsibility.

- Zhu, Chang-You (Beckham) - CPC member 朱常有
- COB/President of QILI HOLDING GROUP
- COB/President of Anhui QILI Stainless Steel Industrial Co., Ltd.
- Executive VP of Wenzhou Shandong Chamber of Commerce
- Member of CPPCC Wenzhou Longwan District Committee (Chinese People's Political Consultative Conference)
- Executive committee of Wenzhou Federation of Industry and Commerce
- President of Jinglai Tennis Association
- National Technical Innovation Enterprise
- Zhejiang SciTech-oriented Small and Medium-sized Enterprise
- Longwan District Excellent Enterprise
- Caring Unit of "YUAN-JU-AI (Love Together)" Charity Alliance
- 2020 Outstanding LUSHANG (Shandong business)
- Leading people of the alien founders in Wenzhou
- Wenzhou New Resident Enterprise
- Zhejiang Sci-Tech Oriented SME





# 齐力控股集团的

The Development History of Qili Holdings Group

# 发展历程

1999~2006年

1999年，朱董才二十一岁，一个勇敢的年轻人希望有一番作为。因此他毅然离开家乡跟随温州一位郑老板来到了东南沿海城市温州打工。这位年轻人一直从事卫生级流体领域等相关技术与生产管理者工作，并深深的爱上这个行业并下定决心要在流体行业干出一番成就。  
2006年底，由于股东分家，被迫选择自己创业艰辛之路！

2007年2月

温州齐力流体设备有限公司注册成立，成立之初仅有三名员工和一台CNC数控及两台普车，与几家贸易公司合作。当初齐力公司的产品通过贸易公司出口到许多国家。

2010年

齐力遇到第一位美国客户，齐力第一次开始独立出口！

2011年

齐力成立锻压工厂。

2014年

开始组建外贸销售团队，以拓展我们的国际业务蓝图。

2015年

开始第三工厂-管件工厂成立，拥有20年不锈钢领域经验的工程师带领他的生产团队加入齐力公司团队。

2017年

齐力制定未来五年发展计划，申请ISO/3A/CE/FDA等国际认证证书。同时设备增至100余台，员工人数增加到75人，也标志着齐力进入快速成长发展高速期。

2018年

第四工厂-球阀工厂成立。

2019年

第五工厂-冲板工厂成立。

2020年

在安徽省开设新厂房（面积30亩），生产厂房及员工住宿15000平方米。  
2020年7月底，正式开始投入批量生产。

2021年

1月正式升级为“齐力控股集团”，9月安徽齐力不锈钢生产基地二期工程启动，计划将安徽生产基地，投产建筑面积扩充至30000平方米，同年12月份齐力控股集团被评选为“国家高新技术企业”。

2022年

齐力第七工厂-BPE/BA管件工厂成立，6月份开始投产。

2023年

在安徽购买新的厂房（面积12亩），齐力第8工厂-锻造工厂成立，同期安徽工厂三期球阀洁净工厂开始投产。

2024年

齐力在新西兰设立第一站海外仓库。

2014至2024年

齐力控股集团2014至2024年用了10年的发展时间，齐力犹如过山车一样突飞猛进，通过董事长多年研究出适合自己企业发展的一套经营方案，围绕主业不断裂变，发展到现在齐力控股集团名下八个独立经营不锈钢制品工厂及5个外贸销售部和一个内贸销售部的团队，至2024年4月底，员工总人数400余人，销售团队38人。

齐力大规划

2024-2028年齐力控股集团在行业各个板块自产自销，大大提高了生产周期及节约了生产成本。齐力也将在国际及国内流体领域独树一帜，坚守初心，合作共赢，发光发热！齐力将秉承专注，专业，专心的工匠精神，做大企业，做强品牌，布局全球国际市场新生态！带领团队共同成长！

1999~2006

In 1999, Mr.Zhu was only 21 years old, and a brave young man hoped to have something to do. Therefore, he resolutely left his hometown and followed a Mr. Zheng from Wenzhou to work in the southeastern coastal city of Wenzhou. This young man has been working as a technical and production manager in the field of hygiene grade fluids, and has deeply fallen in love with this industry and is determined to make achievements in the fluid industry. At the end of 2006, due to shareholder separation, I was forced to choose the arduous path of starting my own business!

February 2007

Wenzhou Qili Fluid Equipment Co., Ltd. was registered and established. At the beginning of its establishment, it only had three employees, one CNC machine, and two conventional cars, and cooperated with several trading companies. Initially, Qili Company's products were exported to many countries through trading companies.

2010

Qi Li encountered its first American customer and started exporting independently for the first time!

2011

Qi Li established a forging and pressing factory.

2014

Start building a foreign trade sales team to expand our international business blueprint.

2015

Starting the establishment of the third factory - pipe fitting factory, an engineer with 20 years of experience in the stainless steel field led his production team to join the Qili company team.

2017

Qi Li has formulated a development plan for the next five years and applied for international certification certificates such as ISO/3A/CE/FDA. At the same time, the number of equipment has increased to over 100, and the number of employees has increased to 75, marking the beginning of a period of rapid growth and development for Qili.

2018

The fourth factory - ball valve factory was established.

2019

The fifth factory-the punching plate factory was established.

2020

Open a new factory building (covering an area of 30 acres) in Anhui Province, with a production plant and employee accommodation of 15000 square meters. At the end of July 2020, mass production officially began.

2021

In January, it was officially upgraded to "Qili Holding Group". In September, the second phase of the Anhui Qili Stainless Steel Production Base project was launched, with plans to expand the production area of the Anhui production base to 30000 square meters. In December of the same year, Qili Holding Group was selected as a "National High Tech Enterprise".

2022

Qili Seventh Factory-BPE/BA Pipe Fitting Factory was established and began production in June.

2023

Purchase a new factory building (covering an area of 12 acres) in Anhui, and establish the Qili 8th Factory - Forging Factory. At the same time, the Anhui Factory Phase III Ball Valve Clean Factory began production.

2024

Qili sets up its first overseas warehouse in New Zealand.

2014~2024

From 2014 to 2024, Qili Holding Group took 10 years of development. Qili has made rapid progress like a roller coaster. Through years of research by the chairman, a set of business plans suitable for the development of their own enterprise has been continuously evolving around their main business, and has now developed into a team of eight independent stainless steel product factories, five foreign trade sales departments, and one domestic trade sales department under Qili Holding Group. By the end of April 2024, the total number of employees is over 400, with a sales team of 38 people.

Qili Grand Plan

From 2024 to 2028, Qili Holdings Group produced and sold products in various sectors of the industry, greatly improving production cycles and saving production costs. Qi Li will also stand out in the international and domestic fluid field, adhere to its original intention, cooperate for mutual benefit, and shine brightly! Qi Li will uphold the spirit of focus, professionalism, and concentration as craftsmen, grow the enterprise, strengthen the brand, and lay out a new ecosystem in the global international market! Leading the team to grow together!



# NATIONAL DISTRIBUTION MAP OF QILI GROUP 齐力集团全国分布图



## ■ 销售分部 SALES DEPARTMENT BRANCHES

1  
温州销售总部  
Wenzhou Sales  
Headquarters

2  
武汉销售分部  
Wuhan Sales  
Branch

3  
重庆销售分部  
Chongqing Sales  
Branch

4  
台湾销售分部  
Taiwan Sales  
Branch

5  
安徽销售分部  
Anhui Sales  
Branch

6  
海口分公司  
Haikou Branch

## 齐力集团旗下8大工厂 QILI 8 INDEPENDENT FACTORIES

不锈钢板冲压工厂  
占地2200平方米  
Stainless Steel Punching  
Factory, 2200m<sup>2</sup>

01

锻造工厂 (阀门和由任毛坯)  
占地12亩 (8000平方米)  
Forging Plant (Valves, Union Parts & Hose Coupling),  
12 Acres (8000m<sup>2</sup>)

02

锻压工厂 (接头和非标件锻造毛坯)  
占地2500平方米  
Forging Factory (Femule, End cap and  
Non-standard Parts), 2500m<sup>2</sup>

03

管件及成型工厂 (弯头/三通/异径/十字)  
占地4500平方米  
Pipe Fitting & Forming Factory (Elbow/Teel/Reducer  
, Cross), 4500m<sup>2</sup>

04

阀门工厂 (球阀、隔膜阀、软管尾部、泵)  
占地6500平方米  
Valve Factory NO.1 (Ball Valve, Diaphragm Valve, Hose  
Tail, Pump), 6500m<sup>2</sup>

05

蝶阀、止回阀、非标件工厂、CNC数控工厂  
占地4200平方米  
Valve Factory NO.2 (Butterfly Valve, Check Valve,  
Non-standard Parts), 4200m<sup>2</sup>

06

安徽管道配件批量生产工厂  
占地30亩  
Anhui Mass Production Factory,  
30 Acres

07

BPE 管件生产工厂  
占地1500平方米  
BPE Fittings Factory,  
1500m<sup>2</sup>

08



# QILI GROUP PROFILE

## 集团简介

齐力控股集团，原温州齐力流体设备有限公司，专业生产卫生级不锈钢各种阀门及管道连接件，为客户提供一站式采购供应链服务，锻造、CNC精加工与销售为一体的八大主力生产工厂，产品远销欧洲，北美洲，南美洲，澳洲等等70多个国家和地区。集团聚焦于卫生级领域多年，解决客户遇到的技术难题是我们的荣幸，目前已获得国家高新企业和32项发明专利及各项国际认证。

产品广泛适用于制药工程，乳制品，食品，饮料，酿酒，糖浆，生物化工，半导体，锂电等领域。所有产品均按3A、BPE、DIN、SMS、ISO、RJT、IDF、BS等标准制造，所有产品均达到GMP药典要求。主要产品有：卫生级泵，阀门系列，管件系列和各种管道连接件。

齐力人会把高质量的材料、先进的设计、严格的制造标准及质量保证体系完美结合，我们始终不会忘记客户给我们的支持与宝贵的意见，对外成就客户，对内成就团队，是企业发展的终身目标，热诚欢迎各位新老顾客莅临指导！

Qili Holding Group, formerly Wenzhou Qili Fluid Equipment Co., Ltd., specializing in the production of various sanitary stainless steel valves and pipeline fittings, providing customers with one-stop procurement supply chain services, forging, CNC finishing and sales as one of the eight main forces Production factories, products are exported to more than 70 countries and regions such as Europe, the North America, South America, and Australia etc. The group has been focusing on the sanitary field for many years, and it is our honor to solve the technical problems encountered by customers. At present, it has obtained 25 national high-tech enterprises and 32 invention patents and various international certifications.

Products are widely used in Pharmaceutical engineering, dairy products, food, beverages, brewing, syrup, biochemistry, semiconductors, lithium batteries and other fields. All products are manufactured according to: 3A,BPE,DIN,SMS,ISO,RJT,IDF,BS and other standards, and all products meet the requirements of GMP pharmacopoeia.The main products are:sanitary pumps, valve series, pipe fittings series and various pipe connectors.

Qili people will perfectly combine high-quality materials, advanced design, strict manufacturing standards and quality assurance system. We will never forget the support and valuable opinions given to us by our customers. We will achieve customers externally and achieve team internally. The lifelong goal of enterprise development, sincerely welcome all new and current customers to visit and guide!



安徽生产基地  
Anhui Production Base

2007

公司创建于(年)  
since (year)

8<sup>+</sup>

制造工厂(家)  
Manufacturing factory(Home)

50000<sup>+</sup>

使用面积(m<sup>2</sup>)  
Usable area (m<sup>2</sup>)

400<sup>+</sup>

员工人数(位)  
Number of employees (bit)

中国·浙江温州  
中国·安徽怀宁



齐力集团总部  
Qili Group Headquarters



# FORGING FACTORY

## 锻造工厂

### • 锻压工厂:

4条生产线, 160吨, 300吨, 400吨, 630吨  
设备锻压1--10寸接头 (14wmp 14mmp 14AMP)

### • 锻造工厂:

4条生产线, 分别是400吨, 630吨, 800吨, 1000吨锻造机器,  
主要锻造蝶阀阀体, 止回阀阀体, 活接, 软管接头及其他非标件等

### • 冲板工厂:

4条生产线

总生产占地面积50000平方米! 公司产品出口70多个国家及地区!



• Forging plant: 4 production lines, 160 tons, 300 tons, 400 tons, 630 tons  
Equipment forging and pressing 1 - 10 inch connector (14wmp 14mmp 14AMP)

• Forging plant: 4 production lines, 400 tons, 630 tons, 800 tons and 1000 tons  
of forging machines, mainly forging butterfly valve bodies, check valve bodies,  
unions, hose joints and other non-standard parts

• Punching plant: 4 production lines

The total production area is 50,000 square meters!  
QIL's products are exported to more than 70 countries and regions!

### 锻造工艺流程 FORGING PROCESS FLOW

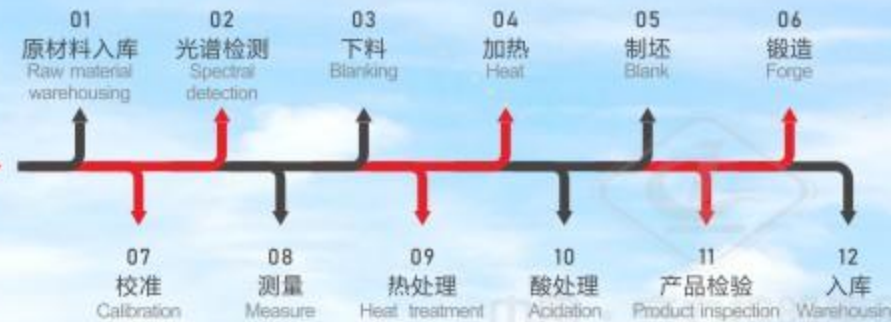

齐力集团锻造工厂  
QILI GROUP FORGING FACTORY





拥有进口/国产CNC数控机床350台

Possess 350 sets of imported CNC machine tools

# PRODUCTION BASE 加工设备

中国·齐力控股集团  
CHINA QILI HOLDING GROUP

高洁净流体设备阀门及管道连接部件解决方案一站式专业制造商  
PROFESSIONAL MANUFACTURER OF SANITARY FLUID VALVE & PIPE FITTING SOLUTIONS

一站式服务  
One stop service

锻造/精加工/销售  
Forging/finishing/sales

精良设备  
Sophisticated equipment

CNC数控及检测设备  
CNC numerical control and testing equipment

制造标准  
Manufacturing standards

3A/BPE/DIN/SMS  
ISO/RJT/IDF/BS

中国·齐力控股集团  
CHINA QILI HOLDING GROUP

雄厚的生产智造水平，是齐力不断突破的源动力。总生产占地面积50000平方米的八大生产车间，配备350余台CNC精密加工车床及各类高精尖智能化设备。在以智造赋能产效跃迁的同时，也用匠心铸就卓越品质。凭借深厚的行业积累与技术沉淀，让每一道工序、每一处细节，都贵注着精湛工艺的创新拓展，也诠释着齐力对品质的完美追求。

The strong level of production intelligence is the driving force behind Qili's continuous breakthroughs. The eight major production workshops with a total production area of 50000 square meters are equipped with over 350 CNC precision machining lathes and various high-precision intelligent equipment. While empowering production efficiency with intelligent manufacturing, we also use craftsmanship to create excellent quality. With profound industry accumulation and technological precipitation, every process and every detail is imbued with the innovation and expansion of exquisite craftsmanship, which also interprets Qili's perfect pursuit of quality.

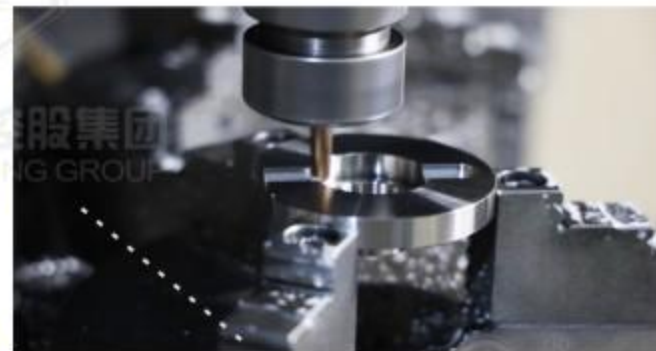

1# CNC Process Workshop



2# CNC Process Workshop



# PIPE FITTING MACHINING CENTER 管件加工中心



## AUTOMATIC POLISHING MACHINE FOR BPE FITTINGS BPE管件自动抛光

高洁净流体设备阀门及管道连接部件解决方案一站式专业制造商  
PROFESSIONAL MANUFACTURER OF SANITARY FLUID VALVE & PIPE FITTING SOLUTIONS

**A**

3A/SMS/DIN标准,  
可做45°/90°/180°弯头,  
3通、4通、大小头。

**B**

表面粗糙值可做  
Ra0.6-0.8, 高精度抛光。

**C**

标准机械化生产,  
严格按照BPE生产要求  
SF1 SF4。

齐力选用进口优质的BPE专用不锈钢原材料,采用行业先进的管道、管件生产加工、自动化的内外表面抛光、电解、清洗设备。结合20多年积累的生产工艺技术经验,严格按照美国ASME BPE-2019标准规范,生产制造高品质SF1和SF4全系列管道、管件产品,确保满足生物制药行业的使用要求。

Qili selects imported high-quality BPE special stainless steel raw materials, adopts the industry's advanced pipeline, pipe fitting production and processing, automatic internal and external surface polishing, electrolysis, cleaning equipment. Combined with more than 20 years of accumulated production technology experience, in strict accordance with American ASME BPE-2019 standard specifications, the production of high-quality SF1 and SF4 full series of pipes, pipe fittings products, to ensure that meet the requirements of the biopharmaceutical industry.

A) 3A/SMS/DIN standard, can do 45°/90°/180° elbow, 3 way, 4 way, size head.  
B) Surface roughness value can be Ra0.6-0.8, high-precision polishing.  
C) Standard mechanized production, in strict accordance with the BPE production requirements SF1 SF4.





# CLEAN WORKSHOP 洁净车间

齐力控股集团，是一家深耕卫生级设备领域多年，专注于生产卫生级不锈钢阀门及管道连接件的领军企业，产品广泛应用于制药、饮料、乳制品、啤酒、生物化工、锂电、半导体等领域。企业在快速发展同时更注重产品的精细化，投入并建设了企业第一个高洁净车间。

Qili Holding Group is a leading enterprise that has been deeply engaged in the field of sanitary equipment for many years, focusing on the production of sanitary stainless steel valves and pipe links, and its products are widely used in pharmaceutical, beverage, dairy, beer, biochemical, lithium battery, semiconductor and other fields. Enterprises in the rapid development at the same time pay more attention to product refinement. Invested and built the company's first high clean workshop.

## 5 其具备5大优势 Having 5 major advantages

产品质量保障  
Product quality assurance

提高生产效率  
Increase productivity

提升工作安全  
Improve work safety

满足行业要求  
Meet industry requirements

提升企业形象  
Enhance corporate image





# INSPECTION AND TESTING 检测检验

中国·齐力控股集团  
CHINA QILI HOLDING GROUP



材质检测  
Material Testing



内窥镜检测  
Endoscopic Inspection



外观检验  
Visual Inspection



尺寸检验  
Dimensional Inspection

公司技术力量雄厚,生产工艺先进,制造设备精良,检测设备完善,售后服务到位,变革不断,创新不断,只为完美呈现高品质的产品。

The company has strong technical strength, advanced production processes, excellent manufacturing equipment, complete testing equipment, and continuous transformation and innovation in after-sales service. Only for the perfect presentation of high-quality products.

中国·齐力控股集团  
CHINA QILI HOLDING GROUP



粗糙度检测  
Roughness Measurement



氦检  
Helium detection



扭矩测试  
Torque testing



压力测试  
Stress testing



# MARKETING NETWORK 营销网络



19 / Professional Manufacturer

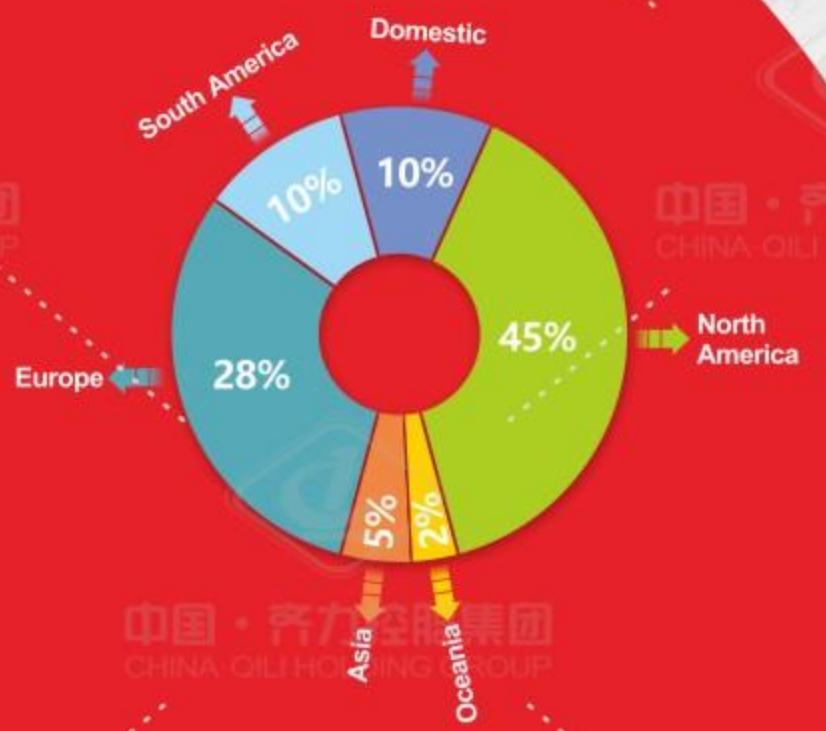

**不断地挑战和创新  
成为客户的前行伙伴**

Continuously challenging and innovating  
Becoming a forward partner for customers





# QILI TEAM 齐力团队

向内生长的驱动力，为齐力提供持续发展的生命力。十余载风雨兼程中，齐力人汇聚起奔涌的时代力量，塑造起和衷共济、相互成就的团队使命与企业担当。坚持互惠共赢的战略伙伴关系，齐力团队以解决切实痛点、保障实际利益、创造巨大价值的理念，与全球客户紧密相连。

The driving force of inward growth provides Qi Li with sustained vitality for development. Over the past decade of trials and tribulations, Qili people have gathered the surging forces of the times, shaping a team mission and corporate responsibility of working together and achieving mutual success. Adhering to a mutually beneficial and win-win strategic partnership, the Qi Li team is closely connected to global customers with the concept of solving practical pain points, safeguarding practical interests, and creating huge value.



□ 以客户价值为中心

Focusing on customer value

□ 以员工价值为基础

Based on employee value

□ 以社会价值为目标

Targeting social values

□ 学习成长颠覆自我

Learning, growth, and self subversion

□ 创新发展成就他人

Innovative development and achievement of others

□ 专业售后维护服务

Professional after-sales maintenance service



# INSPECTION AND TESTING 企业资质



齐力，践行以产品为中心的理念。在持续创新的征途中，始终以自主研发拓展技术边际，先以获得30余项发明专利、多项国内及国际荣誉认证。将严苛的检验标准与质量管理体系相融合，在全流程各阶段中监测品质状况，以客户的角度出发，保障每一个产品的安全稳定。

Qi Li, practice the concept of product as the center. In the journey of continuous innovation, we have always expanded the technological margin with independent research and development, and first obtained more than 30 invention patents and a number of domestic and international honorary certifications. Integrate rigorous inspection standards with a quality management system to monitor quality at all stages of the process. From the customer's point of view, to ensure the safety and stability of each product.

QiLi is Certified by 3A-Sanitary Fittings, Metal Tubing, Check Valve, Ball Valve, Diaphragm Valve







# BUTTERFLY VALVE SERIES 蝶阀系列



扫码查看 更多详情  
Scan the code to view more details

### 产品规格

1/2"~8", DN10-DN200

### Product specifications

1/2"~8", DN10-DN200

### 连接方式

焊接/快装/螺纹/法兰/真空

### Connection method

Welding/Triclamper/Threaded/Flange/Vacuum

### 压力等级

≤1.6mpa

### Pressure Level

≤1.6mpa

### 制造标准

3A/ISO/IDF/DIN/SMS/RJT等

### Manufacturing Standards

3A/ISO/IDF/DIN/SMS/RJT etc.

### 产品材质

SS304/316L

### Product material

SS304/316L

### 驱动方式

手动/气动/电动等

### Drive way

Manual/pneumatic/electric



拉杆式焊接蝶阀  
Pull handle type welded butterfly valve



3片式蝶阀  
3PCS butterfly valve



拉杆式快装蝶阀  
Pull handle type tri clamped butterfly valve



拉杆式外螺纹蝶阀  
Pull handle type threaded butterfly valve



鸭嘴式焊接蝶阀  
Trigger handle type welded butterfly valve



鸭嘴式快装蝶阀  
Trigger handle type tri clamped butterfly valve



鸭嘴式外螺纹蝶阀  
Trigger handle type threaded butterfly valve



不锈钢鸭嘴式快装蝶阀  
SS Trigger handle type tri clamped butterfly valve



三通联动蝶阀  
Three-way butterfly valve



气动快装蝶阀  
Pneumatic tri clamped butterfly valve



气动焊接蝶阀  
Pneumatic welded butterfly valve





# BALL VALVE SERIES 球阀系列



扫码查看 更多详情  
Scan the code to view more details

### 产品规格

1/2"~6", DN10-DN150

### Product specifications

1/2"~6", DN10-DN150

### 连接方式

卡箍/焊接/螺纹/DIN/SMS/ISO/IDF/BSP/RJT

### Connection method

Clamp/welding/thread/DIN/SMS/ISO/IDF/BSP/RJT

### 压力等级

10BAR/1MPa/145PSI/10KG

### Pressure Level

10BAR/1MPa/145PSI/10KG

### 表面

内部CNC加工, 内表面Ra0.6um

### Surface

Internal treatment CNC machining, processing inner surface Ra0.6um

### 材质

304/316L

### Material

304/316L

### 温度

-30°C~200°C

### Temperature

-30°C~200°C



高平台外螺纹球阀  
High platform male thread ball valve



高平台ISO真空球阀  
High Platform ISO Vacuum Ball Valve



加长焊接球阀  
Extended welded ball valve



气动快装球阀  
Pneumatic clamped ball valve



三片式快装高平台球阀  
Three piece tri-clamp high platform ball valve



三片式快装低平台球阀  
Three-piece tri-clamp low-platform ball valve



三片式焊接球阀  
Three-piece welded ball valve



四方三通快装球阀  
Three-way clamp valve



放料球阀/罐底球阀  
Tank bottom ball valve



三通快装球阀  
Three-way clamped ball valve



法兰球阀  
Flange ball valve



锻造焊接球阀  
Forged welded ball valve



衬氟球阀  
PTFE lined ball valve



快装蝶形球阀  
Clamped butterfly type ball valve



快装球阀  
Tri clamp two-way ball valve



外螺纹球阀  
Male thread ball valve



气动快装球阀  
Pneumatic clamped ball valve



气动罐底球阀  
Pneumatic tank bottom ball valve





# DIAPHRAGM VALVE SERIES 隔膜阀系列



扫码查看 更多详情  
Scan the code to view more details

### 产品规格

1/2"~4", DN15-DN100

### Product specifications

1/2"~4", DN15-DN100

### 连接方式

卡箍, 焊接, 螺纹, 3A, BPM, DIN, SMS, IDF, ISO

### Connection method

Clamp welding thread 3A BPM DIN SMS IDF ISO

### 压力等级

10bar(145PSI)

### Pressure Level

10bar(145PSI)

### 阀体结构

直通、三通、U型三通、罐底阀、多通道隔膜阀

### The valve body structure

Straight way, 3 way, U type 3 way, tank bottom valve, Multi-channel diaphragm valve.

### 材质

316L(CF3M)

### Material

316L(CF3M)

### 膜片材料

EPDM+PTFE(双层)EPDM/Silicom/FPM(Vitong)

### Diaphragm material

EPDM+PTFE(double deck)EPDM/Silicon/FPM(Viton)

### 温度

-20°C~150°C

### Applicable temperature

-20°C~150°C

### 认证

3A-54-02/1580

### Certification

3A-54-02/1580

### 新一代隔膜阀New generation Diaphragm valve

齐力公司在2021年对所有的隔膜阀进行了全面的技术升级, 升级后的设计更符合 GMPASMEBPE,EHEDGI以及3A的高洁净技术要求。

### 工作原理Working principle

手动或气动操作, 专门应用于制药工业中的卫生和无菌过程。该阀门非常适用于流体控制 和开关的任务, 膜片提供阀体密封和阀座密封。里面没有路径通到外部环境, 所以该阀适 用于无菌过程, 当阀门关闭时, 支撑膜片的压力垫朝阀体上的密封面移动, 当压力板移动时, 膜片弯曲, 被迫推向阀体中心的阀座区域, 因此关闭了通向阀体的流体路径, 阀体和压力板 的相互关系, 防止了膜片的挤压。

Manual or pneumatic operation, Specially used in sanitary and aseptic processes in the pharmaceutical industry. The valve is ideal for flow body control and switch tasks, diaphragm provides body seal and seat seal. There is no path from inside to the outside environment, so the valve is closed, the pressure pad supporting the diaphragm moves towards the sealing surface of the valve body. When the pressure plate is moved.

The diaphragm bends and is forced to push the seat area in the center of the valve body. Therefore, close the flow path to the valve body, and the relationship between the valve body and pressure plate prevents the diaphragm from squeezing.



手动隔膜阀  
Manual diaphragm valve



焊接锻造隔膜阀  
Welded forged diaphragm valve



手动罐底隔膜阀  
Manual tank bottom diaphragm valve



气动隔膜阀  
Pneumatic diaphragm valve



气动隔膜阀  
Pneumatic diaphragm valve



气动隔膜阀  
Pneumatic diaphragm valve



# CHECK VALVE SERIES CUSTOMIZED PRODUCTS

## 止回阀系列&定制阀门



扫码查看 更多详情  
Scan the code to view more details

在70华氏度的环境温度下，最大工作压力额定值为140磅/平方英寸（取决于阀门尺寸）  
夹端配有预设的EPDM密封件。

规格：连接方式：三角灯/焊接  
1"、1.5"、2"、2.5"、3"或4"尺寸

Maximum operating pressure rating of 140 psi (depending on valve size) at 70 degrees Fahrenheit ambient temperature  
Clamp Ends come with an EPDM seal as preset.

SPECS: Connection: triclamp/welded  
1"/1.5"/2"/2.5"/3" or 4" sizes



减压阀  
Pressure relief check valve



快装止回阀  
Tri clamp check valve



焊接止回阀  
Tri clamp check valve



焊接止回阀  
Check valve middle flange/Weld end



空气止回阀  
Air check valve



3A认证快装止回阀  
3A certified tri clamp check valve



排污止回阀  
Check valve with drain



减压阀  
Clamp "L" body relief valve



Y型止回阀  
Y Ball check valve



防爆阀  
Tank vent



管道内置止回阀  
Cartridge Check Valve



管道适配器  
Pipe adapter



管道适配器的配件  
Fittings for pipe adapters



# UNION PARTS & TRICLAMP WELDING FITTINGS

## 由任活接配件/接头系列



扫码查看 更多详情  
Scan the code to view more details



快装接头/卡箍组件  
Tri clamp fitting/clamp assembly



3A活接头  
3A union



DIN 活接头  
DIN union



RJT 活接头  
RJT union



IDF活接头  
IDF union



14MPHR/14MPHRL皮管接头系列  
Hose couplings



酒用活接头  
Union for wine industry



DIN 由任活接系列  
DIN union



21MP/22MP 接头系列  
Femules



SMS活接头  
SMS union



无菌接头系列  
Aseptic connector series



快装接头系列  
Tri-clamp fittings

高洁净流体设备阀门及管道连接部件解决方案一站式专业制造商  
PROFESSIONAL MANUFACTURER OF SANITARY FLUID VALVE & PIPE FITTING SOLUTIONS



HOSE FITTINGS  
SERIES  
软管接头系列

BPE SERIES  
BPE系列



扫码查看 更多详情  
Scan the code to view more details



扫码查看 更多详情  
Scan the code to view more details



PIPE FITTING  
SERIES  
管件系列



扫码查看 更多详情  
Scan the code to view more details



焊式90°长弯头  
Weld 90° long elbow



焊式45°弯头  
Weld 45°elbow



焊式90°短弯头  
Weld 90° short elbow



焊式45°长弯头  
Weld 45°long elbow



一端焊接一端快装90°弯头  
90°weld x clamp long elbow



一端焊接一端快装45°弯头  
45° weld x clamp elbow



焊式变径三通  
Weld reducing Tee



焊式变径长三通  
Weld long reducing Tee



焊式等径短三通  
Weld short Tee



焊式四通  
Weld cross



180°焊式弯头  
180°weld elbow



焊式同心变径  
Weld concentric reducer



SMS焊式同心变径  
Weld concentric Reducer with tangent



焊式偏心变径  
Weld eccentric Reducer



焊式等径三通  
Weld Tee



卡式等径三通  
Clamp Tee



焊式垂直三通  
Weld y type Tee

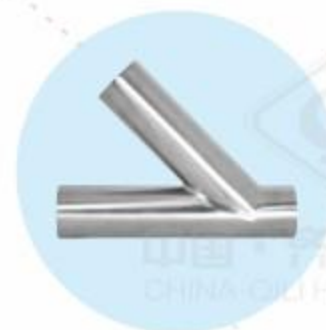

焊式平行三通  
Butt-weld lateral



卡式羊角三通  
Clamp seagull Tee



卡式平行三通  
Clamp lateral



卡式U型三通  
Clamp bottom -outlet u Tee



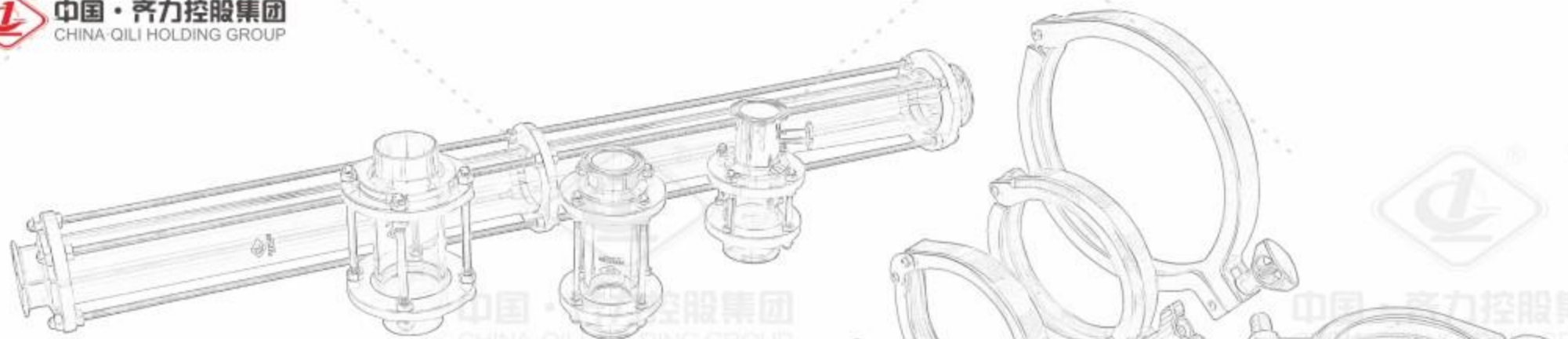

# SIGHT GLASS SERIES CLAMP SERIES

## 视镜系列&卡箍系列



扫码查看 更多详情  
Scan the code to view more details



焊接视镜  
Welding sight glass



快装视镜  
Triclamp sight glass



快装视镜  
Triclamp sight glass



管支架  
Tube holder



管支架  
Tube holder



管支架  
Tube holder



管支架  
Tube holder



高压卡箍  
High pressure clamp



131U卡箍  
131U clamp



单销中间开卡箍  
Single pin clamp



单销对叠卡箍  
Single pin clamp



卡箍接头组  
Clamp set



卡箍接头组  
Clamp set



双销卡箍  
Double pin clamp



单销中间开卡箍  
Single pin open clamp





**PUMP SERIES**  
泵系列



**MANWAY SERIES**  
人孔系列



扫码查看 更多详情  
Scan the code to view more details



扫码查看 更多详情  
Scan the code to view more details